

High Resolution Table Top Scales - Pan Size :190mm x 250mm

0.1g to 15Kg

Features :

- ◆ Incorporate high quality loadcells.
- ◆ Inbuilt battery charger.
- ◆ Auto power off function.
- ◆ Multiple weighing units, gram & carat.
- ◆ Piece counting facility.
- ◆ RS-232 bi directional interface.
- ◆ Power saving mode.
- ◆ Overload and shockload protection.
- ◆ Weight slip printing (Optional).
- ◆ Bright Red LED Display.
- ◆ High bright green LED Display (Optional).
- ◆ Battery Backup (Optional).
- ◆ Additional Display (Optional).

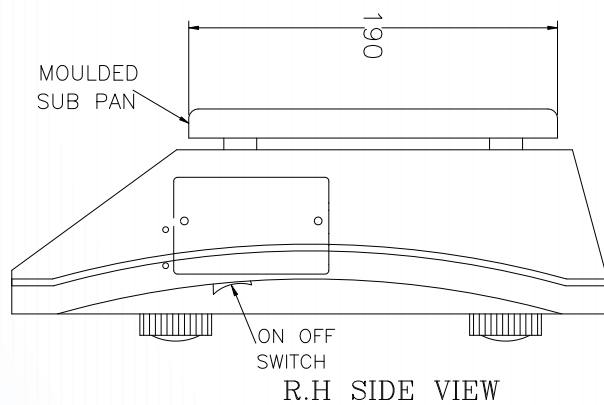
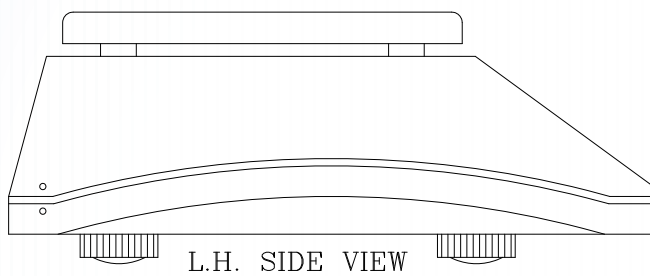
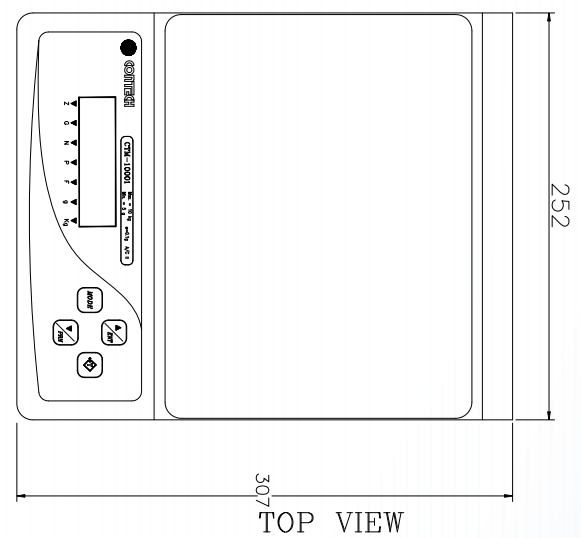
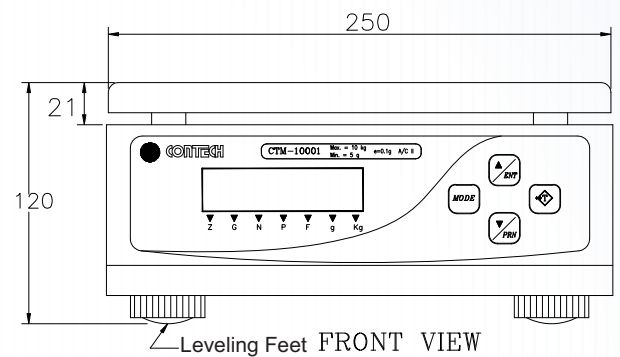

Specifications :

Models	CTM-6001	CTM-6002	CTM-6005	CTT-6K1	CTM-10001	CTM-10002	CTM-10005	CTT-10K1	CTM-15001	CTM-15002	CTM-15005	CTT-15K1
Capacity	6kg	6kg	6kg	6kg	10kg	10kg	15kg	10kg	15kg	15kg	15kg	15kg
Readability	0.1g	0.2g	0.5g	1g	0.1g	0.2g	0.5g	1g	0.1g	0.2g	0.5g	1g
Repeatability (+)	0.1 g	0.2g	0.5g	1g	0.1 g	0.2g	0.5 g	1g	0.1g	0.2g	0.5g	1g
Linearity (±)	0.2 g	0.4g	1.0g	2g	0.2g	0.4g	1.0g	2g	0.2g	0.4 g	1.0 g	2g

Taring Range : Upto full capacity.
 Response Time : 3-5 seconds.
 Power Supply : 90-250V, 50/60Hz
 Power Consumption : 10 Watt
 Operating Temperature : 10-45°C

All Specifications and designs are subject to change for improvement.