

CRANE SCALES with Heat Insulating Shield

- ◆ Rugged aluminum diecast enclosure for Models upto 20 ton.
- ◆ Steel heavy duty enclosure for Models above 20 ton.
- ◆ 25 mm height LED display for Models upto 20 ton & 38 mm height above 20 ton.
- ◆ Maximum safety overload 200%.
- ◆ Inbuilt sealed maintenance free re-chargeable battery and Battery charger (Optional)
- ◆ Infrared remote keypad, operating distance 10 mtr (Optional)
- ◆ RS-232 Interface (Optional)
- ◆ Special construction for high temperature shielding.
- ◆ Minimum distance for normal operation is 2 mtr from a heat radiation source at 1500° C.
- ◆ Heavy duty aluminum diecast enclosure.
- ◆ Multiple print options with Sr. No, Date, Time & Weight in horizontal / vertical mode.
- ◆ Date & Time entry facility.
- ◆ Multiple weighing units.
- ◆ Storage of weights in memory upto 100 samples.
- ◆ Power saving by switching off the display.
- ◆ Automatic zero tracking.
- ◆ Software linearity correction.
- ◆ Display hold facility.
- ◆ Gross & Net Weight function.

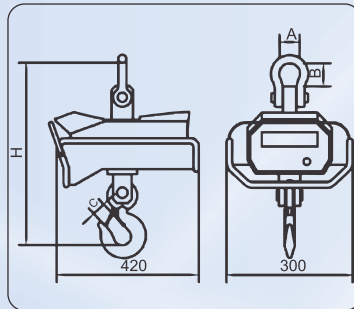
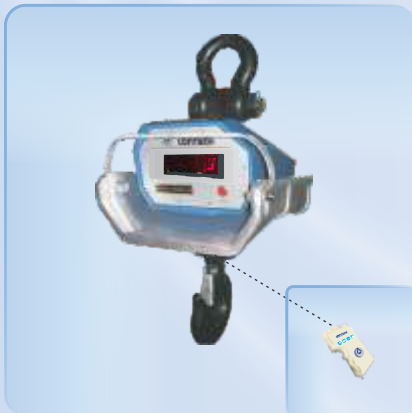

MODELS	CAPACITY	ACCURACY	DIMENSION				NET WT. (Kg)
			H	A	B	C	
CCH-1T200	1 ton	200g	465	56	65	25	26
CCH-2T500	2 ton	500g	490	56	65	32	30
CCH--3T1K	3 ton	1Kg	570	72	90	36	36
CCH-5T2K	5 ton	2Kg	640	90	110	50	42
CCH-10T5K	10 ton	5Kg	920	140	230	60	77
CCH-15T5K	15 ton	5Kg	980	140	230	70	85