

CRANE SCALES Heavy Duty with Wireless Transmission & Heat Insulating Shield

2kg to 30ton

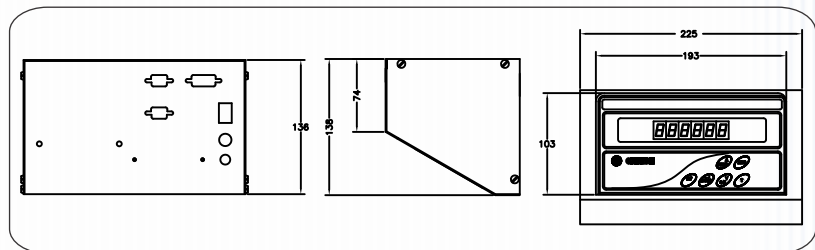
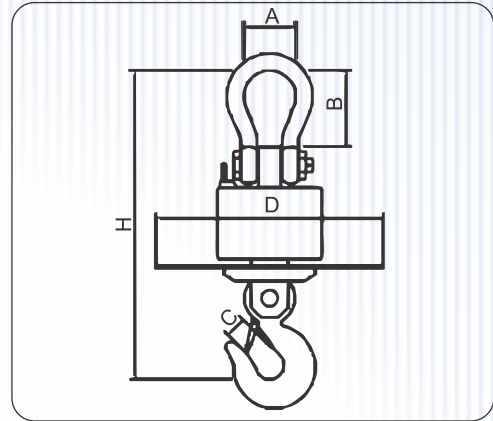

MODELS	CAPACITY	ACCURACY	DIMENSION					NET WT. (Kg)
			H	A	B	C	D	
CCS-5T2K	5 ton	2Kg	700	90	110	50	600	58
CCS-20T5K	20 ton	5Kg	1110	160	260	90	700	180
CCS-30T10K	30 ton	10Kg	1200	180	220	110	800	250

Features :

- ♦ Special construction for high temperature shielding.
- ♦ Minimum distance for normal operation is 2 mtr from a heat radiation source at 1500°C.
- ♦ Wireless transmission maximum operating distance from the Indicator is 100 mtr.
- ♦ Graphical backlite LCD display in the Indicator.
- ♦ Real Time Clock (Optional).

All Specifications and designs are subject to change for improvement.